



Office of the
Deputy Prime Minister

Creating sustainable communities

The Building Regulations 2000

Protection from falling, collision and impact

K

APPROVED DOCUMENT

- K1** **Stairs, ladders and ramps**
- K2** **Protection from falling**
- K3** **Vehicle barriers and loading bays**
- K4** **Protection from collision with open windows,
skylights and ventilators**
- K5** **Protection against impact from and trapping
by doors**

ONLINE VERSION

1998 edition
incorporating 2000
amendments

Contents

	PAGE		PAGE
Use of guidance	2	Protection from collision with open windows, etc. The Requirement K4	14
The Approved Documents	2	Guidance	14
Limitation on requirements	2	Performance	14
Materials and workmanship	2	Section 4: Protection from collision	15
The Workplace (Health, Safety and Welfare) Regulations 1992	3	Introduction to provisions	15
K1 Stairs, ladders and ramps The Requirement K1	4	Projecting parts	15
Guidance	5	Spaces used only for maintenance	15
Performance	5	Protection against impact and trapping by doors The Requirements K5	16
Introduction	5	Guidance	16
Definitions	5	Performance	16
Section 1: Stairs and ladders	6	Section 5: Protection from impact	17
Steepness of stairs – rise and going	6	Introduction to provisions	17
Alternative approach	6	Safety features	17
Construction of steps	6	Standards referred to	18
Headroom	7	DIAGRAMS	
Width of flights	7	1. Measuring rise and going	6
Length of flights	7	2. Measuring headroom	7
Landings	7	3. Reduced headroom for loft conversions	7
Special stairs	8	4. Dividing flights	7
Tapered treads	8	5. Change of direction	7
Spiral and helical stairs	8	6. Landings next to doors	8
Alternating tread stairs	9	7. Cupboard onto landing	8
Fixed ladders	9	8. Measuring tapered treads	8
Handrails for stairs	9	9. Alternating tread stair	9
Guarding of stairs	9	10. Ramp design	10
Access for maintenance purposes	9	11. Guarding design	12
Section 2: Ramps	10	12. Typical locations for containment	13
Pedestrian and Vehicle barriers The Requirements K2/3	11	13. Barrier siting	13
Guidance	11	14. Barrier design	13
Performance	11	15. Loading bay	13
Section 3: Guards and barriers	12	16. Marking by a barrier	15
Pedestrian guarding	12	17. Marking by a surface	15
Guarding of areas used for maintenance	13	18. Doors with vision panels	17
Vehicle barriers	13	TABLE	
Loading bays	13	1. Rise and going	6

Use of guidance

THE APPROVED DOCUMENTS

The Building Regulations 2000 (SI 2000/2531), which came into operation on 1 January 2001, replace the Building Regulations 1991 (SI 1991/2768) and consolidate all subsequent revisions to those regulations. This document is one of a series that has been approved and issued by the Secretary of State for the purpose of providing practical guidance with respect to the requirements of Schedule 1 to and Regulation 7 of the Building Regulations 2000 for England and Wales.

At the back of this document is a list of all the documents that have been approved and issued by the Secretary of State for this purpose.

Approved Documents are intended to provide guidance for some of the more common building situations. However, there may well be alternative ways of achieving compliance with the requirements.

Thus there is no obligation to adopt any particular solution contained in an Approved Document if you prefer to meet the relevant requirement in some other way.

Other requirements

The guidance contained in an Approved Document relates only to the particular requirements of the Regulations which the document addresses. The building work will also have to comply with the requirements of any other relevant paragraphs in Schedule 1 to the Regulations.

There are Approved Documents which give guidance on each of the parts of Schedule 1 and on Regulation 7.

LIMITATION ON REQUIREMENTS

In accordance with Regulation 8, the requirements in Parts A to K and N of Schedule 1 to the Building Regulations do not require anything to be done except for the purpose of securing reasonable standards of health and safety for persons in or about buildings (and any others who may be affected by buildings or matters connected with buildings).

MATERIALS AND WORKMANSHIP

Any building work which is subject to the requirements imposed by Schedule 1 to the Building Regulations should, in accordance with Regulation 7, be carried out with proper materials and in a workmanlike manner.

You may show that you have complied with Regulation 7 in a number of ways. These include the appropriate use of a product bearing CE marking in accordance with the Construction Products Directive (89/106/EEC)¹ as amended by the CE Marking Directive (93/68/EEC)², or a product complying with an appropriate technical specification (as defined in those Directives),

a British Standard, or an alternative national technical specification of any state which is a contracting party to the European Economic Area which, in use, is equivalent, or a product covered by a national or European certificate issued by a European Technical Approval issuing body, and the conditions of use are in accordance with the terms of the certificate. You will find further guidance in the Approved Document supporting Regulation 7 on materials and workmanship.

Independent certification schemes

There are many UK product certification schemes. Such schemes certify compliance with the requirements of a recognised document which is appropriate to the purpose for which the material is to be used. Materials which are not so certified may still conform to a relevant standard.

Many certification bodies which approve such schemes are accredited by UKAS.

Technical specifications

Building Regulations are made for specific purposes: health and safety, energy conservation and the welfare and convenience of disabled people. Standards and technical approvals are relevant guidance to the extent that they relate to these considerations. However, they may also address other aspects of performance such as serviceability, or aspects which although they relate to health and safety are not covered by the Regulations.

When an Approved Document makes reference to a named standard, the relevant version of the standard is the one listed at the end of the publication. However, if this version has been revised or updated by the issuing standards body, the new version may be used as a source of guidance provided it continues to address the relevant requirements of the Regulations.

The appropriate use of a product which complies with a European Technical Approval as defined in the Construction Products Directive will meet the relevant requirements.

The Department intends to issue periodic amendments to its Approved Documents to reflect emerging harmonised European Standards. Where a national standard is to be replaced by a harmonised European Standard, there will be a co-existence period during which either standard may be referred to. At the end of the co-existence period the national standard will be withdrawn.

¹ As implemented by the Construction Products Regulations 1991 (SI 1991/1620).

² As implemented by the Construction Products (Amendment) Regulations 1994 (SI 1994/3051).

THE WORKPLACE (HEALTH, SAFETY AND WELFARE) REGULATIONS 1992

The Workplace (Health, Safety and Welfare) Regulations 1992 contain some requirements which affect building design. The main requirements are now covered by the Building Regulations, but for further information see: *Workplace health, safety and welfare, The Workplace (Health, Safety and Welfare) Regulations 1992, Approved Code of Practice and Guidance*; The Health and Safety Commission, L24; Published by HMSO 1992; ISBN 0-11-886333-9.

The Workplace (Health, Safety and Welfare) Regulations 1992 apply to the common parts of flats and similar buildings if people such as cleaners and caretakers are employed to work in these common parts. Where the requirements of the Building Regulations that are covered by this part do not apply to dwellings, the provisions may still be required in the situations described above in order to satisfy the Workplace Regulations.

Mixed use development

In mixed use developments part of a building may be used as a dwelling while another part has non-domestic use. In such cases, if the requirements of this part of the Regulations for dwellings and non-domestic use differ, the requirements for non-domestic use should apply in any shared parts of the building.

The Requirement K1

This Approved Document deals with the following Requirement from Part K of Schedule 1 to the Building Regulations 2000.

<i>Requirement</i>	<i>Limits on application</i>
Stairs, ladders and ramps K1. Stairs, ladders and ramps shall be so designed, constructed and installed as to be safe for people moving between different levels in or about the building.	Requirement K1 applies only to stairs, ladders and ramps which form part of the building.

Where necessary reference should be made to Approved Document B: Fire safety, and Approved Document M: Access and facilities for disabled people.

Note: Attention is drawn to the Workplace (Health, Safety and Welfare) Regulations 1992

Compliance with Building Regulation requirement K1 and, where appropriate, requirement M2 where it relates to stairs and ramps would, in accordance with Section 23(3) of the Health and Safety at Work, etc. Act 1974, prevent the service of an improvement notice with regard to the requirements of Regulation 17 of the Workplace (Health, Safety and Welfare) Regulations 1992 which relate to permanent stairs, ladders and ramps on pedestrian traffic routes within the workplace premises, including those used to give access for maintenance to parts of the workplace premises.

Guidance

Performance

In the Secretary of State's view the requirement K1 will be met by the use of stairs, ladders and ramps in appropriate circumstances to afford reasonable safety between levels in the following buildings:

- a. dwellings where the difference in level is more than 600mm;
- b. other buildings where the change of level is two or more risers (or 380mm if not part of a stair).

An acceptable level of safety can be achieved by different standards of provision, depending on the circumstances; for example, in a public building the standard of provision may be higher than in a dwelling, to reflect the lesser familiarity and greater number of users.

Where access is required only for the purpose of maintenance, greater care can be expected from those gaining access, and it would be reasonable that less demanding provisions could satisfy the requirement.

Introduction

0.1 This document describes some ways of meeting the requirement.

Section 1 gives guidance on aspects of geometry of stairs, special stairs and guarding of stairs.

Section 2 gives guidance on ramps and guarding of ramps.

0.2 The requirement does not apply to means of access outside a building unless the access is part of the building; for example, the requirement does not apply to steps on land leading to a building, but does apply to entrance steps which are part of the building.

0.3 Where access routes:

- a. form part of a means of escape in case of fire, reference should be made to Approved Document B: Fire safety;
- b. are intended as a means of access for disabled people, reference should be made to Approved Document M: Access and facilities for disabled people.

0.4 In places where a stair or ramp forms part of the means of access within assembly buildings, such as sports stadia, arenas, theatres, cinemas, etc., it should conform to the guidance in Part K: Protection from falling, collision and impact.

However, where steps are part of the gangways serving areas for spectators or there needs to be special consideration given to guarding in spectator areas, then reference should be made to relevant guidance such as:

- a. for new assembly buildings, BS 5588-6:1991 Fire precautions in the design, construction and use of buildings. Code of Practice for places of assembly;
- b. for work to existing assembly buildings, *Guide to Fire Precautions in Existing Places of Entertainment and Like Premises*, Home Office 1990;
- c. for stands at sports grounds, *Guide to Safety at Sports Grounds*, The Stationery Office 1997.

Definitions

0.5 The following meanings apply to terms throughout this Approved Document.

Alternating tread stair A stair with paddle shaped treads with the wide portion alternating from one side to the other on consecutive treads (see paragraphs 1.22–1.24).

Containment A barrier that prevents people falling from one floor to the storey below (see Diagrams 11 and 12).

Flight The part of a stair or ramp between landings that has a continuous series of steps or a continuous slope (for the widths and lengths of flights see paragraphs 1.11–1.14).

Going The horizontal dimensions from front to back of a tread less any overlap with the next tread above (for measurement of the going on tapered treads see paragraphs 1.18–1.20).

Helical stair A stair that describes a helix round a central void (see paragraph 1.21).

Ladder A means of access to another level formed by a series of rungs or narrow treads on which a person normally ascends or descends facing the ladder (see paragraphs 1.25 and 1.26).

Ramp A slope steeper than 1 in 20 designed to conduct a pedestrian or wheelchair user from one level to another (see Section 2).

Rise The height between consecutive treads (see paragraphs 1.1–1.6).

Spiral stair A stair that describes a helix round a central column (see paragraph 1.21).

Stair A succession of steps and landings that makes it possible to pass on foot to other levels.

Tapered tread A step in which the nosing is not parallel to the nosing of the step or landing above it (see paragraphs 1.18–1.20).

Section 1: Stairs and ladders

Steepness of stairs – rise and going

1.1 The requirement will be satisfied if, in a flight, the steps all have the same rise and the same going to the dimensions shown in 1.3 or comply with 1.4 and 1.5.

1.2 Three categories of stairs are considered in this Approved Document:

'Private' intended to be used for only one dwelling.

'Institutional and assembly' serving a place where a substantial number of people will gather.

'Other' in all other buildings.

1.3 Indication of the practical limits for rise and going, for each category of stair which satisfies the requirements, is given below.

a. **Private stair:** Any rise between 155mm and 220mm used with any going between 245mm and 260mm; or

Any rise between 165mm and 200mm used with any going between 223mm and 300mm.

b. **Institutional and assembly stair:** Any rise between 135mm** and 180mm** used with any going between 280mm and 340mm.

c. **Other stair:** Any rise between 150mm** and 190mm** used with any going between 250mm and 320mm.

1.4 Table 1 gives the maximum rise and minimum going for the three stair categories.

Table 1 Rise and going

		Maximum rise (mm)	Minimum going (mm)
1.	Private stair	220†	220†
2.	Institutional and assembly stair	180**	280*
3.	Other stair	190**	250

Note:

† The maximum pitch for private stair is 42°.

* If the area of a floor of the building is less than 100m², the going may be reduced to 250mm.

** For maximum rise for stairs providing the means of access for disabled people, reference should be made to Approved Document M: Access and facilities for disabled people.

Diagram 1 Measuring rise and going

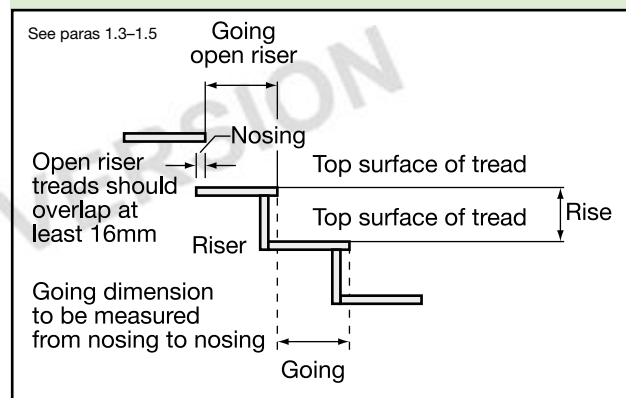

1.5 The normal relationship between the dimensions of the rise and going is that twice the rise plus the going ($2R + G$) should be between 550mm and 700mm.

Diagram 1 shows how to measure the rise and going (for steps with tapered treads, see also paragraphs 1.18–1.20).

1.6 In assembly buildings, the gangways may need to be at different pitches to maintain sightlines for spectators and this may affect the main stairs, etc.

The maximum pitch for gangways for seated spectators is 35°.

Alternative approach

1.7 The requirement for steepness of stairs can be met by following the relevant recommendations in BS 5395-1:1977 Stairs, ladders and walkways. Code of practice for the design of straight stairs.

Construction of steps

1.8 Steps should have level treads. Steps may have open risers, but treads should then overlap each other by at least 16mm. For steps in buildings providing the means of access for disabled people reference should be made to Approved Document M, Access and facilities for disabled people.

1.9 All stairs which have open risers and are likely to be used by children under 5 years should be constructed so that a 100mm diameter sphere cannot pass through the open risers.

Headroom

1.10 A headroom of 2m is adequate on the access between levels (see Diagram 2). For loft conversions where there is not enough space to achieve this height, the headroom will be satisfactory if the height measured at the centre of the stair width is 1.9m reducing to 1.8m at the side of the stair as shown in Diagram 3.

Diagram 2 Measuring headroom

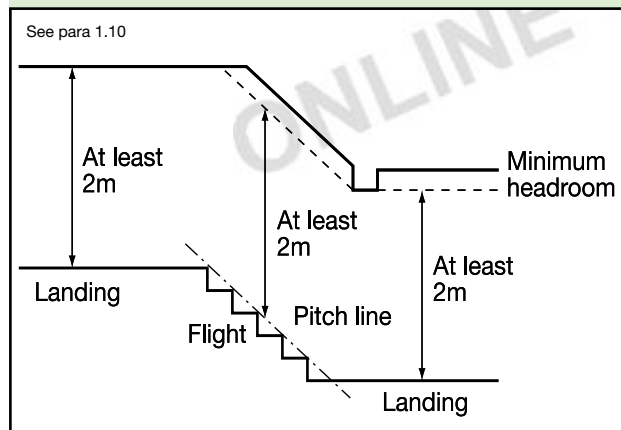
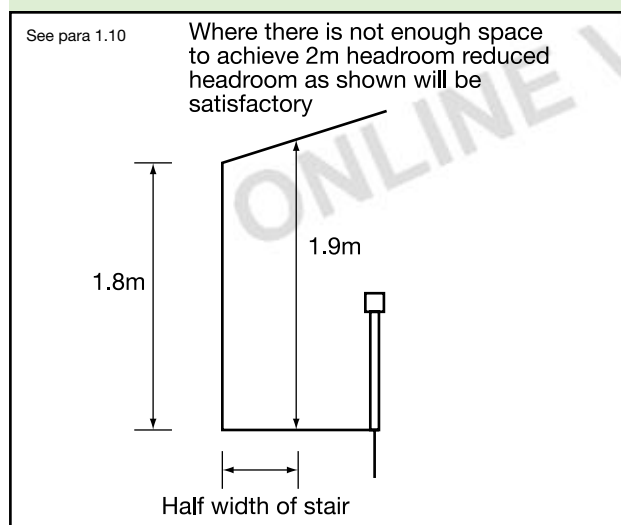

Diagram 3 Reduced headroom for loft conversions



Width of flights

1.11 No recommendations for minimum stair widths are given. Designers should bear in mind the requirements for stairs which:

- form part of means of escape. Reference should be made to Approved Document B: Fire safety;
- provide access for disabled people. Reference should be made to Approved Document M: Access and facilities for disabled people.

1.12 A stair in a public building which is wider than 1800mm should be divided into flights which are not wider than 1800mm as shown in Diagram 4.

Diagram 4 Dividing flights

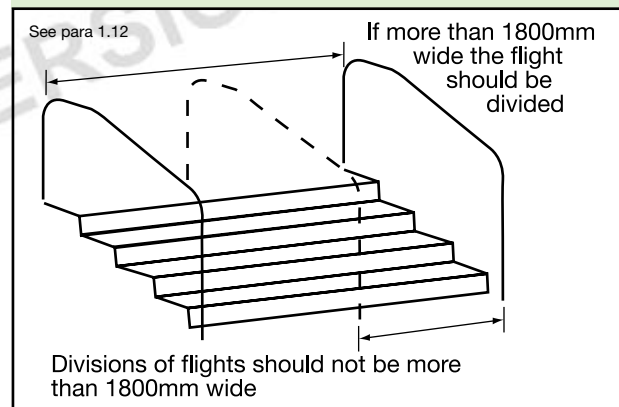

Length of flights

1.13 The number of risers in a flight should be limited to 16 if a stair serves an area used as a shop or for assembly purposes.

For gangways of shallow pitch that are used in assembly buildings reference should be made to BS 5588-6:1991 and to the *Guide to Safety in Sports Grounds* and *Guide to Fire Precautions in Existing Places of Entertainment and Like Premises*.

1.14 Stairs having more than 36 risers in consecutive flights should make at least one change of direction between flights of at least 30° (see Diagram 5).

Diagram 5 Change of direction

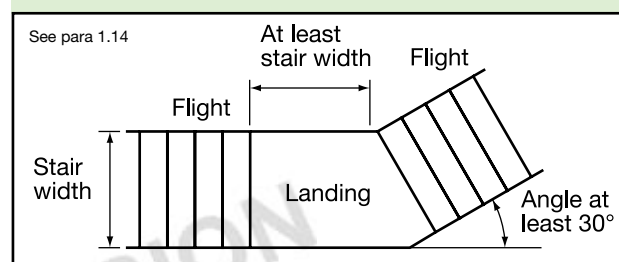

Landings

1.15 Landings should be provided at the top and bottom of every flight. The width and length of every landing should be at least as great as the smallest width of the flight. The landing may include part of the floor of the building.

1.16 To afford safe passage landings should be clear of permanent obstruction. A door may swing across a landing at the bottom of a flight but only if it will leave a clear space of at least 400mm across the full width of the flight (see

K1 STAIRS AND LADDERS

Diagram 6). Doors to cupboards and ducts may open in a similar manner over a landing at the top of a flight (see Diagram 7). For means of escape requirements reference should be made to Approved Document B: Fire safety.

1.17 Landings should be level unless they are formed by the ground at the top or bottom of a flight. The maximum slope of this type of landing may be 1 in 20 provided that the ground is paved or otherwise made firm.

Diagram 6 Landings next to doors

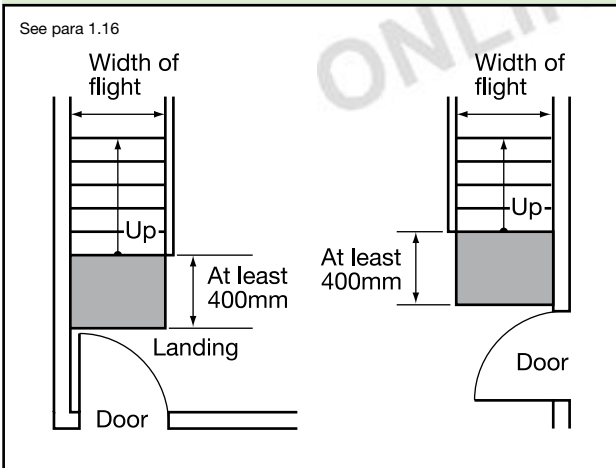
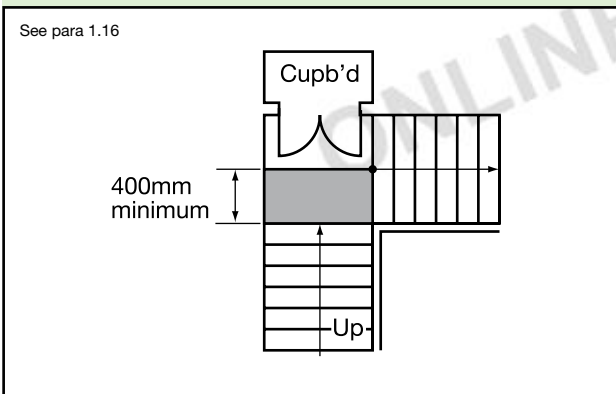

Diagram 7 Cupboard onto landing



Special stairs

Tapered treads

1.18 For steps with tapered treads the going should be measured as follows:

- if the width of flight is narrower than 1m measure in the middle; and
- if the width of flight is 1m or wider measure 270mm from each side.

The requirement will be satisfied if the rise and going complies with advice in paragraphs 1.1 to 1.5.

The going of tapered treads should measure at least 50mm at the narrow end (see Diagram 8).

1.19 Where consecutive tapered treads are used a uniform going should be maintained.

1.20 Where a stair consists of straight and tapered treads the going of the tapered treads should not be less than the going of the straight flight – these treads should satisfy paragraphs 1.1 to 1.5.

Stairs designed to BS 585-1:1989 Wood stairs. Specification for stairs with closed risers for domestic use, including straight and winder flights and quarter or half landings, will offer reasonable safety.

Diagram 8 Measuring tapered treads

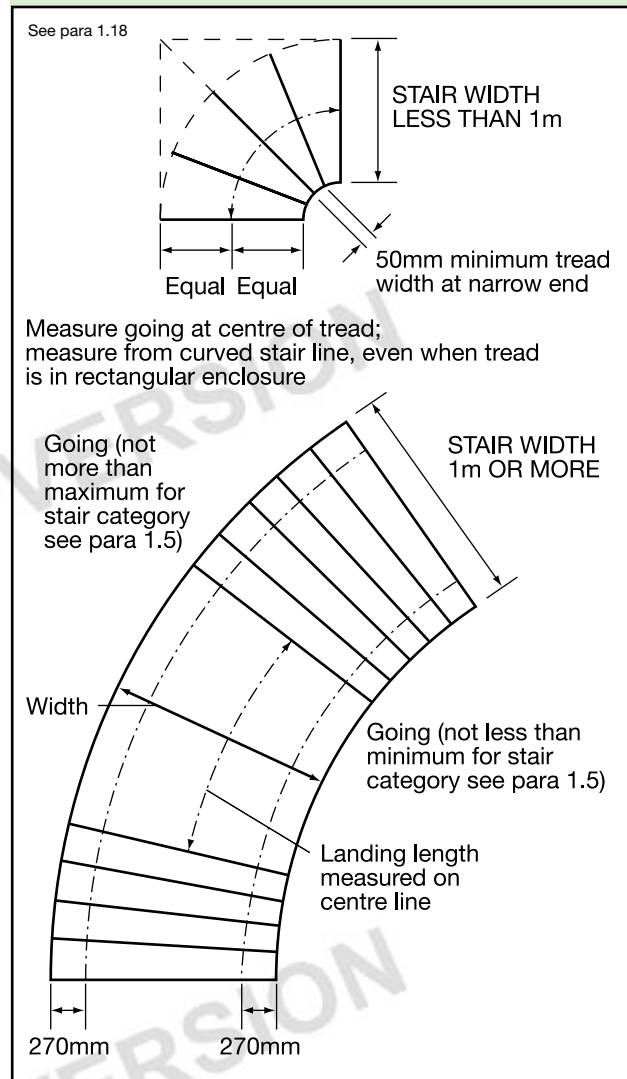

Spiral and helical stairs

1.21 Stairs designed in accordance with BS 5395-2:1984 Stairs, ladders and walkways. Code of practice for the design of helical and spiral stairs will be adequate.

Stairs with goings less than shown in this standard may be considered in conversion work when space is limited and the stair does not serve more than one habitable room.

Alternating tread stairs

1.22 This type of stair is one of a number of stair types designed to save space. The general pattern of steps has alternate handed steps with part of the tread cut away; the user relies on familiarity and regular use for reasonable safety (see Diagram 9).

1.23 Alternating tread stairs should only be installed in one or more straight flights for a loft conversion and then only when there is not enough space to accommodate a stair satisfying paragraphs 1.1 to 1.17 above. It should only be used for access to one habitable room, together if desired with a bathroom and/or a WC. This WC must not be the only WC in the dwelling.

1.24 Steps should be uniform with parallel nosings. The stair should have handrails on both sides and the treads should have slip resistant surfaces. The tread sizes over the wider part of the step should be in line with dimensions shown in Table 1 with a maximum rise of 220mm and a minimum going of 220mm. The provisions stated in paragraph 1.9 will apply.

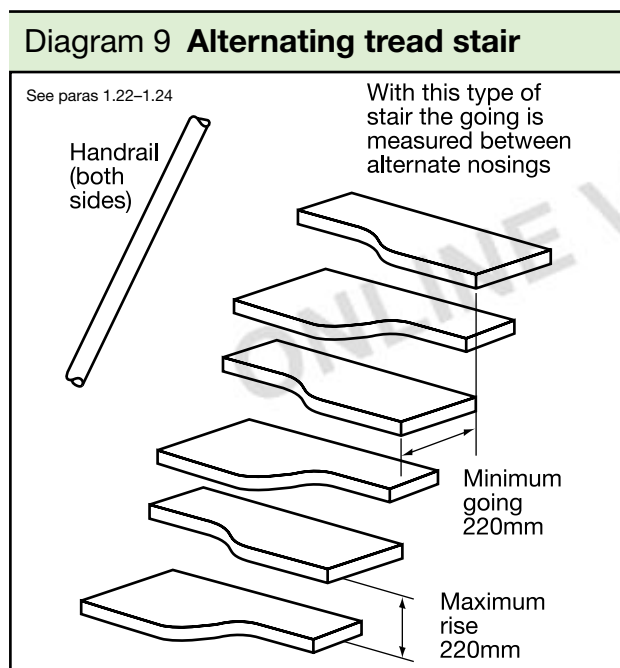

Fixed ladders

1.25 A fixed ladder should have fixed handrails on both sides and should only be installed for access in a loft conversion and then only when there is not enough space without alteration to the existing space to accommodate a stair which satisfies paragraphs 1.1 to 1.17. It should be used for access to only one habitable room. Retractable ladders are not acceptable for means of escape. For reference see Approved Document B: Fire safety.

1.26 Stairs, ladders and walkways in industrial buildings should, as appropriate, be designed and constructed in accordance with BS 5395-3:1985

Stairs, ladders and walkways. Code of practice for the design of industrial stairs, permanent ladders and walkways, or BS 4211:1987 Specification for ladders for permanent access to chimneys, other high structures, silos and bins.

Handrails for stairs

1.27 Stairs should have a handrail on at least one side if they are less than 1m wide. They should have a handrail on both sides if they are wider. Handrails should be provided beside the two bottom steps in public buildings and where stairs are intended to be used by people with disabilities. See Approved Document M: Access and facilities for disabled people. Elsewhere handrails need not be provided beside the two bottom steps.

In all buildings handrail height should be between 900mm and 1000mm measured to the top of the handrail from the pitch line or floor.

Handrails can form the top of a guarding if the heights can be matched.

Guarding of stairs

1.28 Flights and landings should be guarded at the sides (see Diagram 11):

- in dwellings – when there is a drop of more than 600mm;
- in other buildings – when there are two or more risers.

1.29 Except on stairs in a building which is not likely to be used by children under 5 years the guarding to a flight should prevent children being held fast by the guarding. The construction should be such that:

- a 100mm sphere cannot pass through any openings in the guarding; and
- children will not readily be able to climb the guarding.

1.30 The height of the guarding itself should be as shown in Diagram 11.

Access for maintenance purposes

1.31 Where frequent access for maintenance will be required (e.g. at least once per month), provisions such as those suggested for private stairs in dwellings in this Approved Document, or the guidance in BS 5395-3 on industrial stairs and ladders, will satisfy the requirement.

1.32 Where access will be required less frequently it may be appropriate to use portable ladders, etc. Provisions for safe use of such temporary means of access are not covered by Building Regulations, but they are covered by the Construction (Design and Management) Regulations 1994.

Section 2: Ramps

2.1 Steepness To permit safe passage the steepest slope of ramp that should be used is 1:12.

2.2 Headroom All ramps and landings should have a clear headroom throughout of at least 2m (see Diagram 10).

2.3 Width There is no recommendation for minimum ramp widths, except for ramps which form means of escape; for reference, see Approved Document B: Fire safety. For ramps providing access for disabled people see Approved Document M: Access and facilities for disabled people.

2.4 Obstruction of ramps Ramps should be clear of permanent obstructions.

2.5 Handrails Ramps that are less than 1m wide should have a handrail on at least one side. They should have a handrail on both sides if they are wider. There is no need to have handrails if the rise of the ramp is 600mm or less.

Handrails should be at a height of between 900mm and 1000mm. They should give firm support and allow a firm grip. Handrails can form the top of the guarding if the heights can be matched. For handrails on ramps providing access for disabled people see Approved Document M: Access and facilities for disabled people.

2.6 Landings Ramps should be provided with landings (see paragraphs 1.15–1.17).

2.7 Guarding Ramps and their landings should be guarded at their sides in the same way as stairs (see paragraphs 1.28–1.30).

Diagram 10 Ramp design

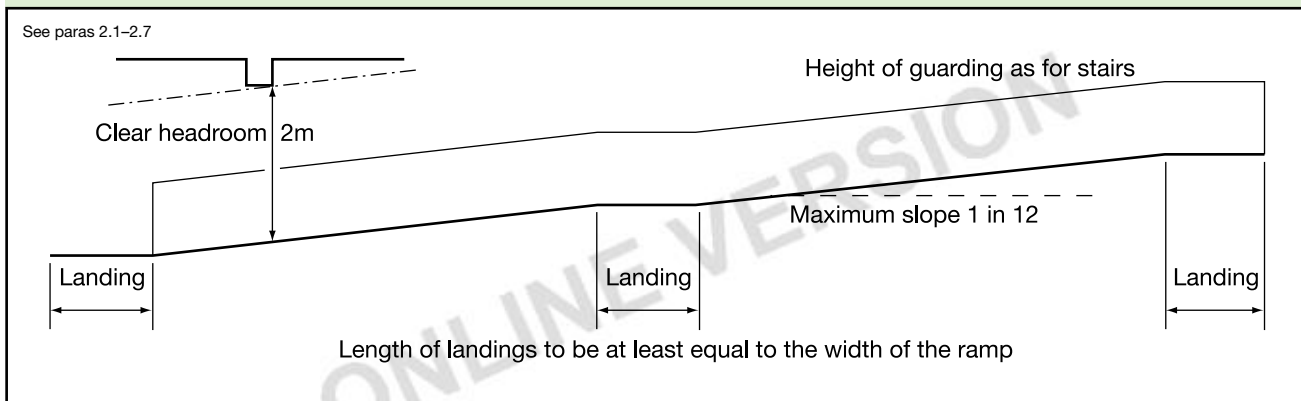

The Requirements K2 and K3

This Approved Document deals with the following Requirements from Part K of Schedule 1 to the Building Regulations 2000.

<i>Requirement</i>	<i>Limits on application</i>
<p>Protection from falling</p> <p>K2. (a) Any stairs, ramps, floors and balconies and any roof to which people have access, and</p> <p>(b) any light well, basement area or similar sunken area connected to a building, shall be provided with barriers where it is necessary to protect people in or about the building from falling.</p> <p>Vehicle barriers and loading bays</p> <p>K3. (1) Vehicle ramps and any levels in a building to which vehicles have access, shall be provided with barriers where it is necessary to protect people in or about the building.</p> <p>(2) Vehicle loading bays shall be constructed in such a way, or be provided with such features, as may be necessary to protect people in them from collision with vehicles.</p>	<p>Requirement K2(a) applies only to stairs and ramps which form part of the building.</p>

Note: Attention is drawn to the Workplace (Health, Safety and Welfare) Regulations 1992

Compliance with Building Regulation requirement K2 would, in accordance with Section 23(3) of the Health and Safety at Work, etc. Act 1974, prevent the service of an improvement notice relating to guarding with regard to the requirements for protection from the risk of falling a distance likely to cause personal injury in Regulation 13 of the Workplace (Health, Safety and Welfare) Regulations 1992.

Compliance with Building Regulation requirement K3 (2) would, in accordance with Section 23(3) of the Health and Safety at Work, etc. Act 1974, prevent the service of an improvement notice relating to the design of loading bays under Regulation 17 of the Workplace (Health, Safety and Welfare) Regulations 1992.

Guidance

Performance

In the Secretary of State's view the requirements of K2 and K3 will be met if, in order to reduce the risk to the safety of people in and about buildings:

- pedestrian guarding is provided in dwellings which is capable of preventing people from being injured by falling from a height of more than 600mm; and
- pedestrian guarding is provided in other buildings which is capable of preventing people from falling more than the height of two risers (or 380mm, if not part of a stair);
- vehicle barriers are provided which are capable of resisting or deflecting the impact of vehicles;

- loading bays are provided with an adequate number of exits or refuges which enable people to avoid being struck or crushed by vehicles.

An acceptable level of safety can be achieved by different standards of provision for guarding, depending on the circumstances; for example, in a public building the standard of provision may be higher than in a dwelling, to reflect the lesser familiarity and greater number of users.

For areas where access is required only for the purpose of maintenance, greater care can be expected from those gaining access, and it would be reasonable that less demanding provisions could satisfy the requirement.

Section 3: Guards and barriers

Pedestrian guarding

3.1 Siting Guarding should be provided where it is reasonably necessary for safety to guard the edges of any part of a floor (including the edge below an opening window), gallery, balcony, roof (including rooflights and other openings), any other place to which people have access and any light well, basement area or similar sunken area next to a building. Guarding should also be provided in vehicle parks, but not on any ramps used only for vehicle access. Guarding need not be provided to such places as loading bays where it would obstruct normal use.

3.2 Design Any wall, parapet, balustrade or similar obstruction may serve as guarding. Guarding should be at least the height shown in Diagram 11. Guarding should be capable of resisting at least the horizontal force given in BS 6399-1:1996. Where glazing is used in the guarding, reference should be made to Approved Document N: Glazing – safety in relation to impact, opening and cleaning.

For further guidance on design of barriers and infill panels, reference should be made to BS 6180:1995 *Code of practice for protective barriers in and about buildings*.

Diagram 11 Guarding design

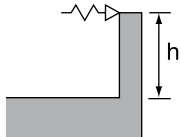
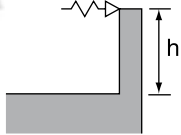
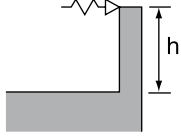
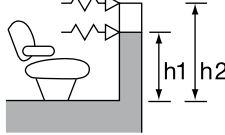
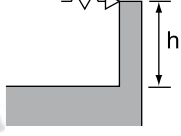
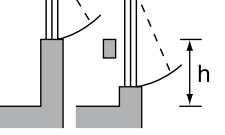
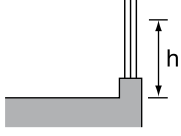
Building category and location		Height (h)	
Single family dwellings	Stairs, landings, ramps, edges of internal floors	900mm for all elements	
	External balconies and edges of roof	1100mm	
Factories and warehouses (light traffic)	Stairs, ramps	900mm	
	Landings and edges of floor	1100mm	
Residential, institutional, educational, office, and public buildings	All locations	900mm for flights otherwise 1100mm	
Assembly	530mm in front of fixed seating	800mm (h1)	
	All other locations	900mm for flights elsewhere 1100mm (h2)	
Retail	All locations	900mm for flights otherwise 100mm	
Glazing in all buildings	At opening windows except roof windows in loft extensions, see Approved Document B1	800mm	
	At glazing to changes of level to provide containment (see Diagram 12)	Below 800mm	

3.3 Where buildings are likely to be used by children under 5 years the guarding should prevent children being held fast by the guarding. The construction should be such that a 100mm sphere cannot pass through any opening in the guarding and so that children will not readily be able to climb it. Horizontal rails for such guarding should be avoided.

Diagram 12 Typical locations for containment

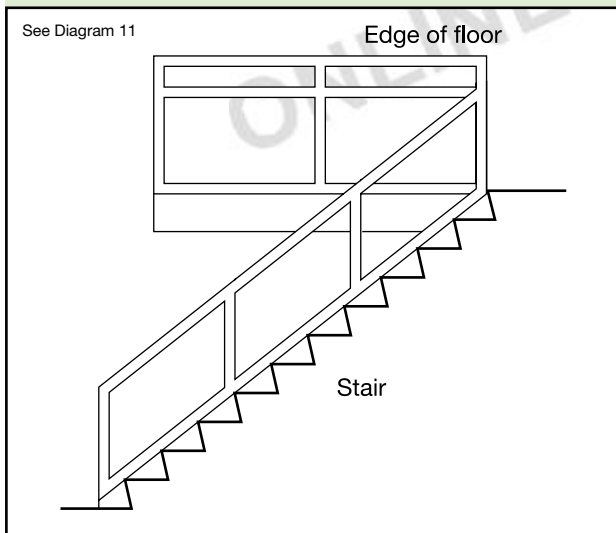

Guarding of areas used for maintenance

3.4 Where frequent access for maintenance will be required (e.g. at least once per month), provisions such as those suggested for dwellings in this Approved Document (see Diagram 11) will satisfy the requirement.

3.5 Where access for maintenance will be required less frequently, it may be appropriate to use temporary types of guarding or warning notices. Provisions for such measures are not covered by Building Regulations, but they are covered by the Construction (Design and Management) Regulations 1994.

3.6 Information on signs is given in the Health and Safety (Signs and Signals) Regulations 1996.

Diagram 13 Barrier siting

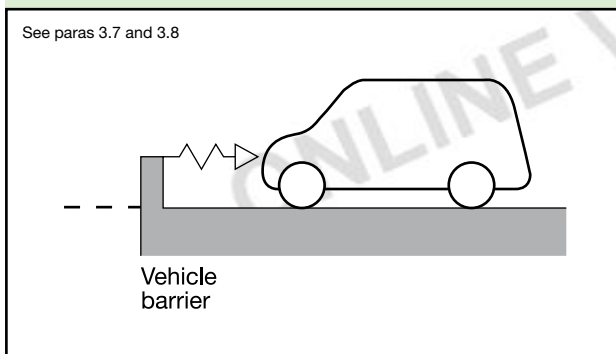

Vehicle barriers

3.7 Siting: If vehicles have access to a floor, roof or ramp which forms part of a building, barriers should be provided to any edges which are level with or above the floor or ground or any other route for vehicles (see Diagram 13).

3.8 Design: Any wall, parapet, balustrade or similar obstruction may serve as a barrier.

Barriers should be at least the height shown in Diagram 14 and should be capable of resisting forces set out in BS 6399-1:1996 Loading for buildings. Code of practice for dead and imposed loads.

Diagram 14 Barrier design

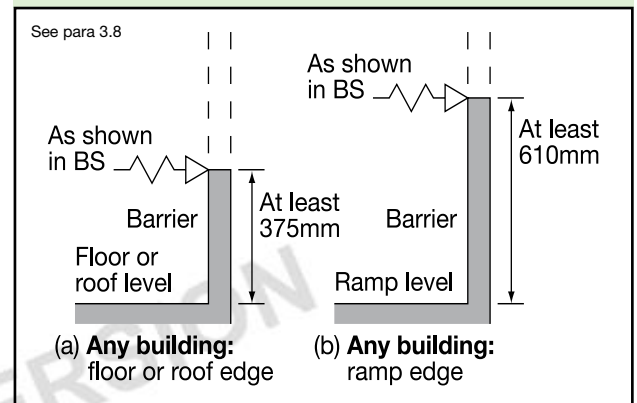

Loading bays

3.9 Design: Loading bays should be provided with at least one exit point from the lower level (preferably near the centre of the rear wall). Wide loading bays (e.g. those for three or more vehicles) should be provided with at least two exit points, one being at each side. Alternatively, a refuge should be provided which people can use to avoid being struck or crushed by a vehicle (see Diagram 15).

Diagram 15 Loading bay

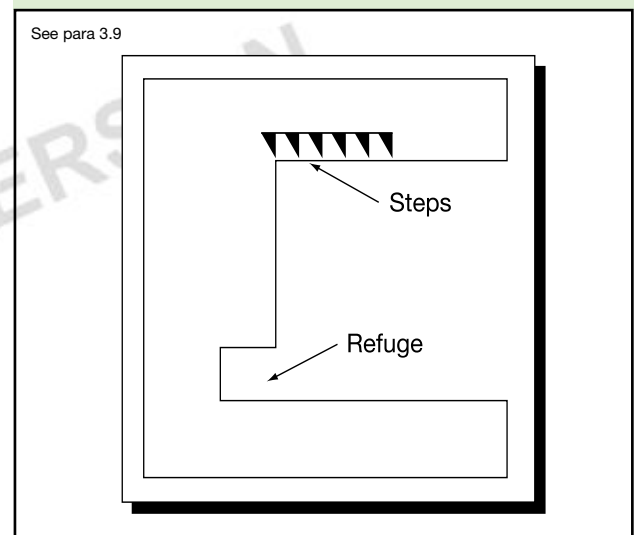

The Requirement K4

This Approved Document deals with the following Requirements from Part K of Schedule 1 to the Building Regulations 2000.

<i>Requirement</i>	<i>Limits on application</i>
Protection from collision with open windows, etc. K4. Provision shall be made to prevent people moving in or about the building from colliding with open windows, skylights or ventilators.	Requirement K4 does not apply to dwellings.

Where necessary, reference should be made to Approved Document B: Fire safety, for guidance on clear dimensions of escape routes; and Approved Document M: Access and facilities for disabled people, for guidance on hazards on access routes.

Note: **Attention is drawn to the Workplace (Health, Safety and Welfare) Regulations 1992**

Compliance with Building Regulation requirement K4 would, in accordance with Section 23(3) of the Health and Safety at Work, etc. Act 1974, prevent the service of an improvement notice with regard to the requirements for projecting windows, skylights and ventilators covered by regulation 15(2) of the Workplace (Health, Safety and Welfare) Regulations 1992.

Guidance

Performance

In the Secretary of State's view, requirement K4 will be met if windows, skylights and ventilators can be left open without danger of people colliding with them. This could be achieved by:

- installing windows, etc. so that projecting parts are kept away from people moving in and around the building; or
- installing features which guide people moving in or about the building away from any open window, skylight or ventilator.

In special cases, such as spaces used only for maintenance purposes, greater care can be expected by those gaining access and it would be reasonable that less demanding provisions could satisfy the requirement.

Section 4: Protection from collision

Introduction to provisions

4.1 This Approved Document sets out some ways of complying with the requirement for windows, skylights and ventilators.

Projecting parts

4.2 Parts of windows, skylights and ventilators that project either internally or externally more than about 100mm horizontally into spaces which are used by people moving in or about the building should be:

- not less than 2m above the ground or floor when in any fixed position; or
- marked by a feature such as a barrier or rail about 1100mm high to prevent people walking into the projecting part (see Diagram 16); or
- marked by provision of surfaces with strong tactile differences or by suitable landscaping features, so that people are guided away from them (see Approved Document M and Diagram 17).

Spaces used only for maintenance

4.4 In spaces which are used infrequently, and only for the purpose of maintenance, provisions such as clear marking of the projecting part to make it easy to see will satisfy the requirement.

Diagram 16 **Marking by a barrier**

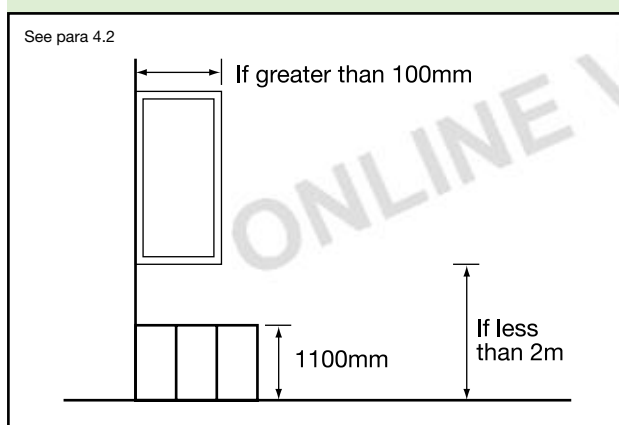
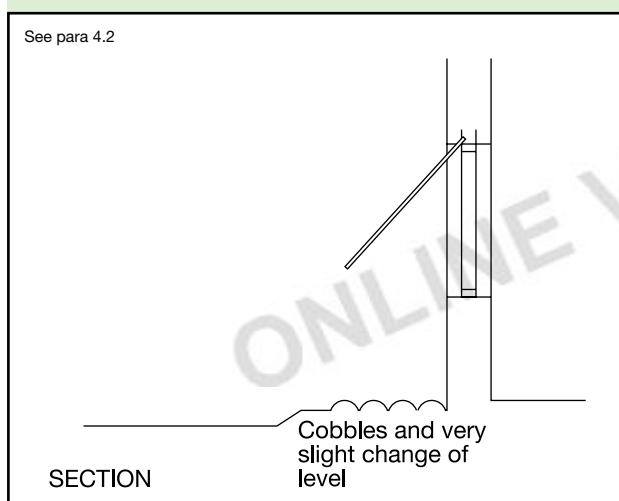

Diagram 17 **Marking by a surface**



The Requirement K5

This Approved Document deals with the following Requirement from Part K of Schedule 1 to the Building Regulations 2000.

Requirement	Limits on application
Protection against impact from and trapping by doors	
K5. (1) Provision shall be made to prevent any door or gate: (a) which slides or opens upwards, from falling onto any person; and (b) which is powered, from trapping any person. (2) Provision shall be made for powered doors and gates to be opened in the event of a power failure. (3) Provision shall be made to ensure a clear view of the space on either side of a swing door or gate.	Requirement K5 does not apply to: (a) dwellings or (b) any door or gate which is part of a lift.

Where necessary, reference should be made to: Part B *Fire Safety* (B1: *Means of escape* has additional guidance for doors on escape routes) and Part M *Access and facilities for disabled people* (M2: *Access and use* has additional guidance on the design of internal and external doors).

Note: **Attention is drawn to the Workplace (Health, Safety and Welfare) Regulations 1992**

Compliance with Building Regulation requirement K5 would, in accordance with Section 23(3) of the Health and Safety at Work, etc. Act 1974, prevent the service of an improvement notice with regard to the requirements for doors and gates in Regulation 18 of the Workplace (Health, Safety and Welfare) Regulations 1992.

Guidance

Performance

In the Secretary of State's view, requirement K5 will be satisfied if measures are taken to prevent the opening and closing of doors and gates presenting a safety hazard.

Section 5: Protection against impact

Introduction to provisions

5.1 This Approved Document sets out some ways of complying with the requirement for suitable construction of doors and gates.

Safety features

5.2 Provision of features such as the following will satisfy the requirement:

- a. doors and gates on main traffic routes and those which can be pushed open from either side should have vision panels unless they are low enough to see over (typically 900mm for a person in a wheelchair). Guidance on the size of vision panels suitable for use by disabled people is given in Approved Document M (see Diagram 18);
- b. sliding doors and gates should have a stop or other effective means to prevent them coming off the end of the track. They should also have a retaining rail to prevent them falling should the suspension system fail or the rollers leave the track;
- c. upward opening doors and gates should be fitted with a device to stop them falling in a way that could cause injury;
- d. power operated doors and gates should have:
 - safety features to prevent injury to people who are struck or trapped (such as a pressure sensitive door edge which operates the power switch);
 - a readily identifiable and accessible stop switch;
 - provision for manual or automatic opening in the event of a power failure where and when necessary for health or safety.

Diagram 18 Doors with vision panels

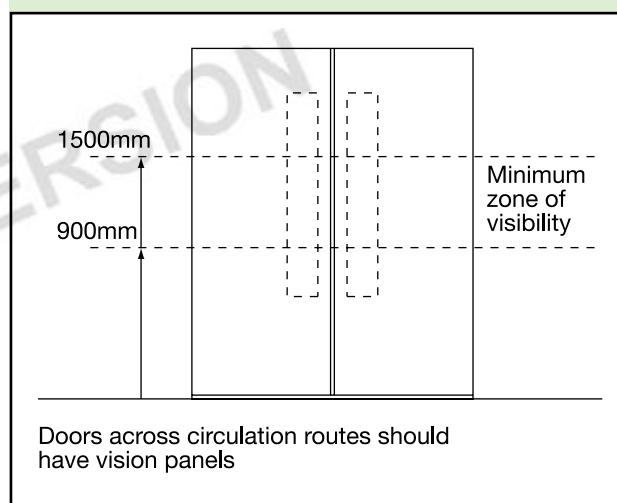

Standards referred to

BS 585-1:1989

Wood stairs. Specification for stairs with closed risers for domestic use, including straight and winder flights and quarter and half landings. AMD 6510 1990. Obsolescent.

BS 4211:1987

Specification for ladders for permanent access to chimneys, other high structures, silos and bins. AMD 7064 1992.
(Withdrawn and superseded by BS4211:1994.
Withdrawn and superseded by BS 4211:2005
Specification for permanently fixed ladders.)

BS 5395-1:1977

Stairs, ladders and walkways. Code of practice for the design of straight stairs. AMD 3355 1980, AMD 4450 1984.
(Withdrawn and superseded by BS 5395-1:2000
Stairs, ladders and walkways. Code of practice for the design, construction and maintenance of straight stairs and windows.)

BS 5395-2:1984

Stairs, ladders and walkways. Code of practice for the design of helical and spiral stairs. AMD 6076 1989.

BS 5395-3:1985

Stairs, ladders and walkways. Code of practice for the design of industrial type stairs, permanent ladders and walkways. AMD 14247 2003.
(Partially replaced by BS EN ISO 14122-1:2001
Safety of machinery. Permanent means of access to machinery. Choice of fixed means of access between two levels. BS EN ISO 14122-2:2001
Safety of machinery. Working platforms and walkways. BS EN ISO 14122-3:2001
Safety of machinery. Permanent means of access to machinery stairways, stepladders and guard-rails.)

BS 5588-6:1991

Fire precautions in the design, construction and use of buildings. Code of practice for places of assembly. AMD 10212 1998, AMD 10443 1999, AMD 14990 2004.

BS 6180: 1995

Code of practice for barriers in and about buildings. (Withdrawn and superseded by BS 6180:1999
Barriers in and about buildings. Code of practice. AMD 13292 2001.)

BS 6399-1:1996

Loading for buildings. Code of practice for dead and imposed loads. AMD 13669 2002.

Published by NBS, part of RIBA Enterprises Ltd, and available from:

RIBA Bookshops Mail Order

15 Bonhill Street
London EC2P 2EA

Telephone orders/General enquiries: 020 7256 7222

Fax orders: 020 7374 2737

Email orders: sales@ribabookshops.com

Or order online at:

www.thebuildingregs.com

ONLINE VERSION

RIBA Bookshops

66 Portland Place, London W1B 1AD. Telephone 020 7256 7222.

113-115 Portland Street, Manchester M1 6DW. Telephone 0161 236 7691.

Birmingham & Midland Institute, Margaret Street, Birmingham B3 3SP. Telephone 0121 233 2321.

RSUA, 2 Mount Charles, Belfast BT7 1NZ. Telephone 028 9032 3760.

Renew Rooms, 82 Wood Street, Liverpool L1 4DQ. Telephone 0151 707 4380.

VERSION

ISBN-10 1 85946 210 3
ISBN-13 978 1 85946 210 2
Stock code 56663

© Crown copyright 2006

The Approved Documents are published by NBS for the Office of the Deputy Prime Minister.

This publication has been approved by Ministers and has official status. Copyright in the contents, the cover, the design and the typographical arrangement of this publication rests with the Crown unless otherwise stated. The contents of this publication may be reproduced free of charge in any format or medium for the purposes of private research and study or for internal circulation within an organisation. This is subject to the contents being reproduced accurately and not in a way that implies official status. Any publisher wishing to reproduce the content of this publication must not use or replicate the ODPM crest or replicate the official version's style and appearance, including the cover design, and must not present their publication as being an official publication as this may confuse the public. The reproduced material must be acknowledged as Crown Copyright and the title of the publication specified. The Office of the Deputy Prime Minister does not accept any responsibility for the accuracy and comprehensiveness of any other versions.

Any other use of the contents of this publication would require a copyright licence. Please apply for a licence by writing to the Office of Public Sector Information, Information Policy Team, St Clements House, 2-16 Colegate, Norwich NR3 1BQ. Fax 01603 723000 or email HMSOlicensing@cabinet-office.x.gsi.gov.uk. Further information can be obtained from www.opsi.gov.uk.

NBS

www.thenbs.com

ISBN 1-859462-10-3



9 781859 462102 >